



Using a dictionary

Dictionaries are useful for checking **spellings** and for finding the **meanings of words**.

1. Some of these words are spelt correctly, but others are not.

Use a dictionary to **check** each **spelling**.

Tick each word spelt correctly and write the correct spelling for the others.

- a) heard _____
- b) earth _____
- c) freind _____
- d) diffrent _____
- e) follow _____
- f) suddinly _____
- g) baloon _____
- h) through _____
- i) stoped _____
- j) somtimes _____



2. Learn the correct spelling of each word in question 1.

Use the **Look, Say, Cover, Write, Check** strategy.

3. **Write your own definition** for each of these words.

Check your answers with a dictionary.

- a) important _____
- b) garden _____
- c) morning _____
- d) clothes _____
- e) hungry _____
- f) stroll _____
- g) joke _____
- h) suitcase _____
- i) shower _____
- j) cottage _____

My reading journal

- Use this page to help you write your reading journal.

Name _____

Class _____ Date _____

Title _____

Author _____

Fiction/Non-fiction _____

What is the book about?

For a fiction book, list some of the characters.

What are the characters like?
Give evidence.

For a non-fiction book, say if the information was easy or difficult to understand. Give reasons.

Now write your final thoughts about the book.



- Use your notes to write a longer piece about the book.

Teachers' note Discuss the reasons for writing a reading journal and why the various sections of the journal are important, for example: why is it important to put the date? The children should be made aware of the features of the journal and the kind and quality of information required. Each child could produce a reading journal for the books read for a class topic.

Developing Literacy
Text Level Year 5
© A & C Black 2000

me _____

Types of angle

Colour:
the **acute** angles red,
the **obtuse** angles blue,
the **reflex** angles yellow.

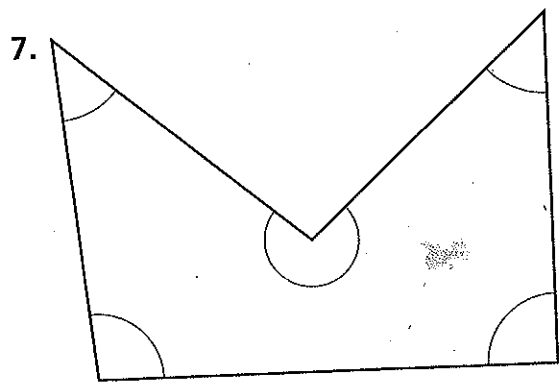
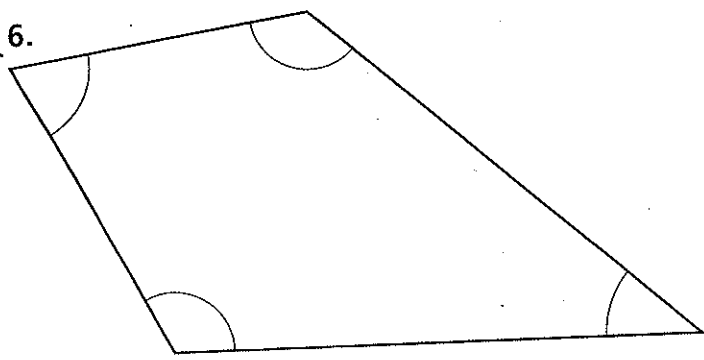
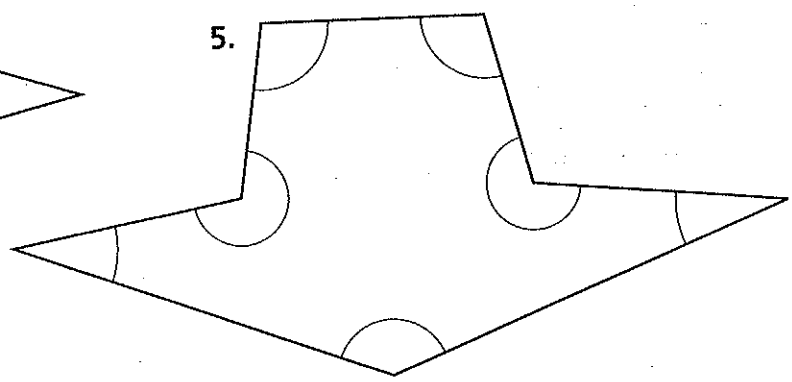
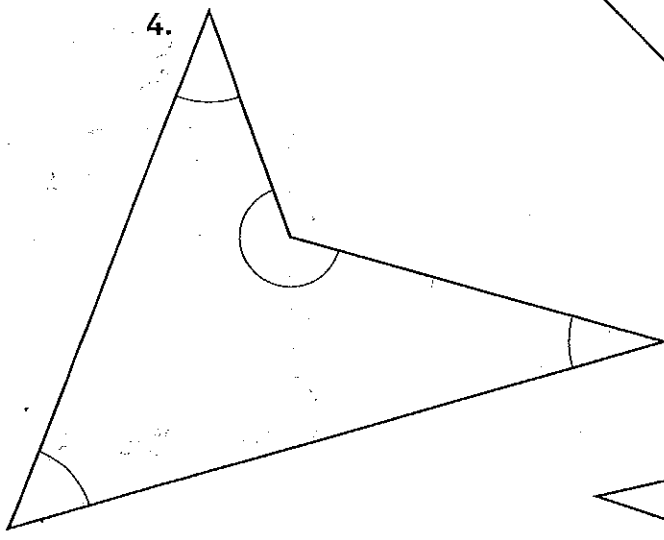
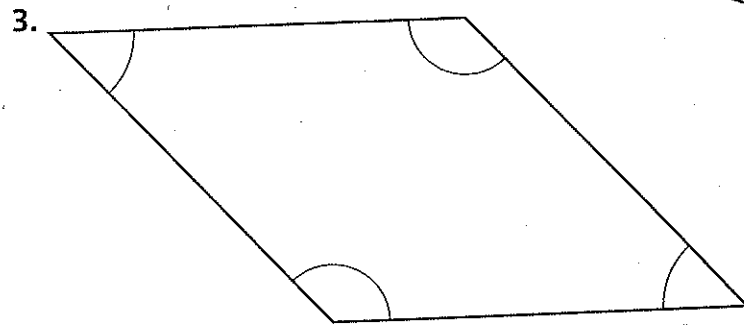
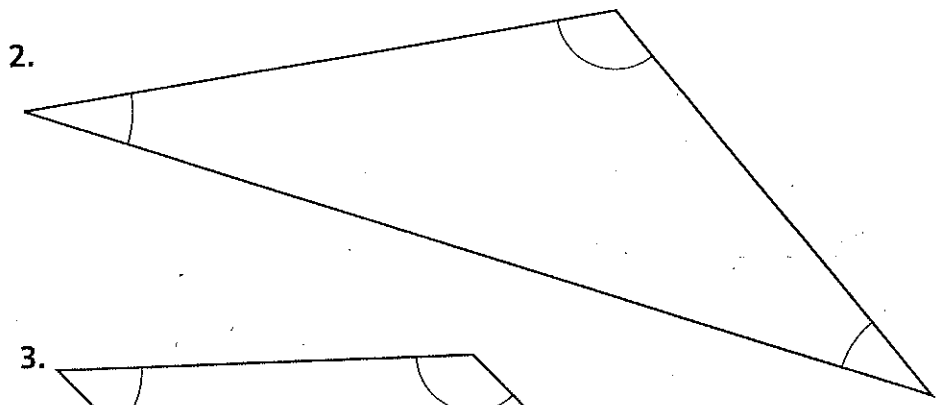
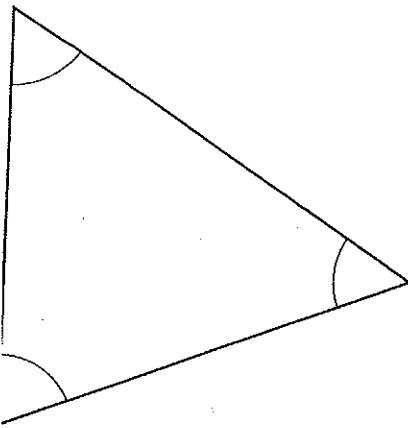

Alien angles

Draw a path from each alien to its space ship.

Look at the shaded angles.

Use a different colour for each alien.

They can move vertically, horizontally or diagonally.

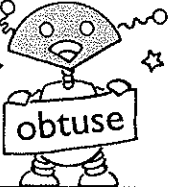
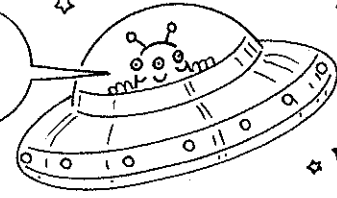

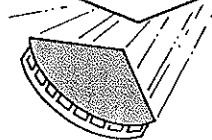
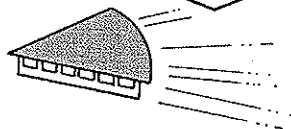
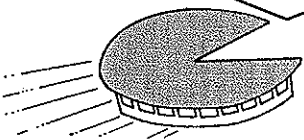

Teachers' note Ensure the children understand that the shaded angles must match the alien's sign. A clock face with moveable hands can be used to introduce the page. Explain the fact that any time there are two angles between the hands, a larger and a smaller one. Discuss, while rotating the hands, at what times the smaller angle is acute and at what times it is obtuse.

Angles

Write the missing angles.

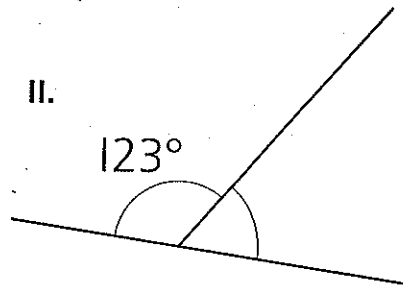
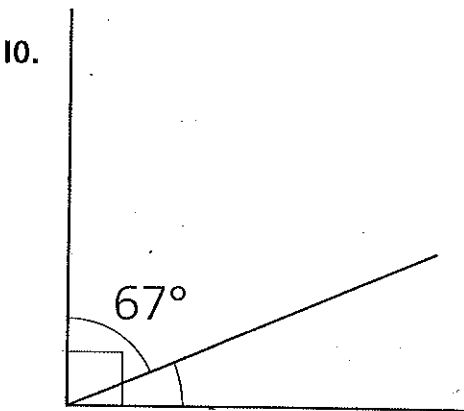
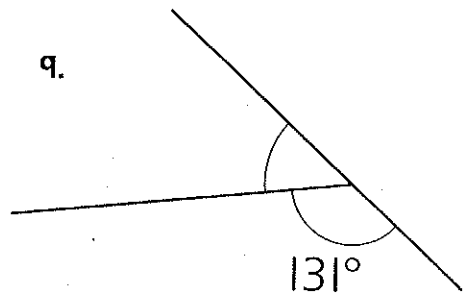
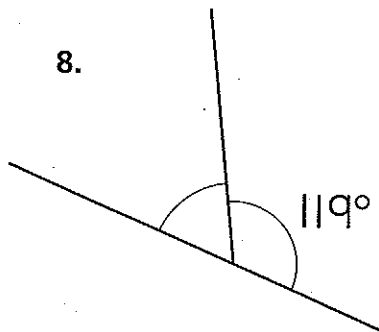
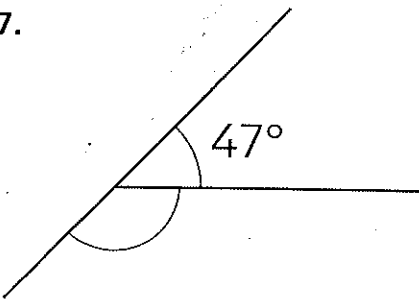
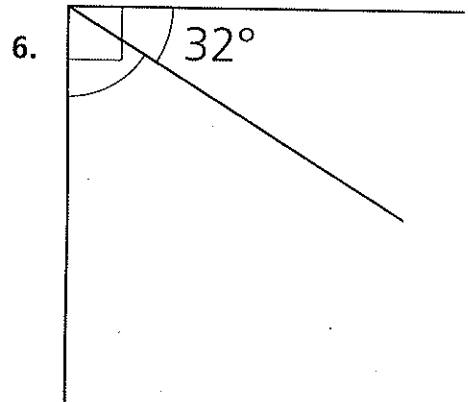
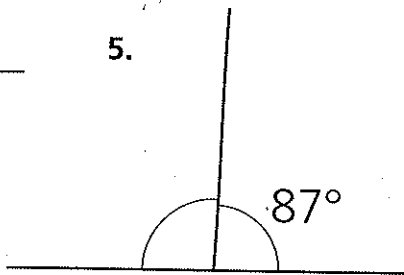
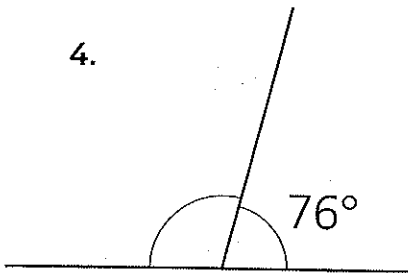
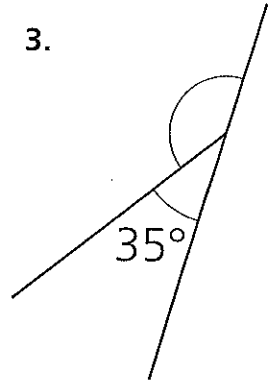
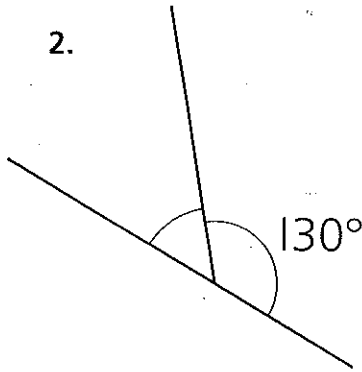
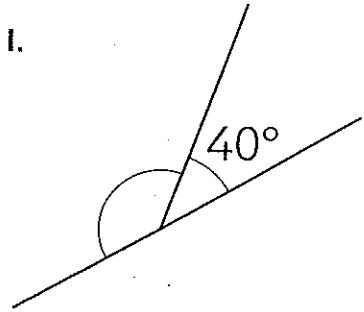

Name _____

Measuring angles

Estimate the order of these angles, smallest to largest.

Write the letter.

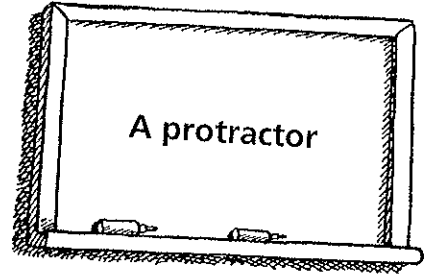

smallest

largest

Estimate									
Measure									

Then measure and write the size of each.

Was your order correct?

